

HH-2 45 T4 0,37kW (280454206)

GENERAL DATA



EXTERNAL MOTOR, VARIABLE PITCH BLADES

MANUFACTURING FEATURES:

- Long case fan.
 - Transmission ball bearings set inside a sealed cast iron box.
 - Cast aluminium impeller with variable pitch angle in origin.
 - Polyester powder finishing coat.
 - Standard asynchronous squirrel-cage motor with IP-55 protection and Class F insulation.
- Manufactured with standard voltages: 230/400V 50Hz for three phase motors up to 4kW and 400/690V 50Hz for higher powers.
- Inspection door.

APPLICATIONS:

Designed for inline installation, they are suitable for:

- Air renewal in buildings and industries.
- Extraction of hot air up to 90°C.
- Maximum working temperature: carried air: 90°C, ambient 60°C.

UNDER REQUEST:

- Supply impeller (air direction from impeller to motor),
- Reversible impeller.
- Polyamide impeller.
- 60Hz fans and special voltages.
- 2 speed motors.
- Hot-dipped galvanised.

PERFORMANCE CURVE

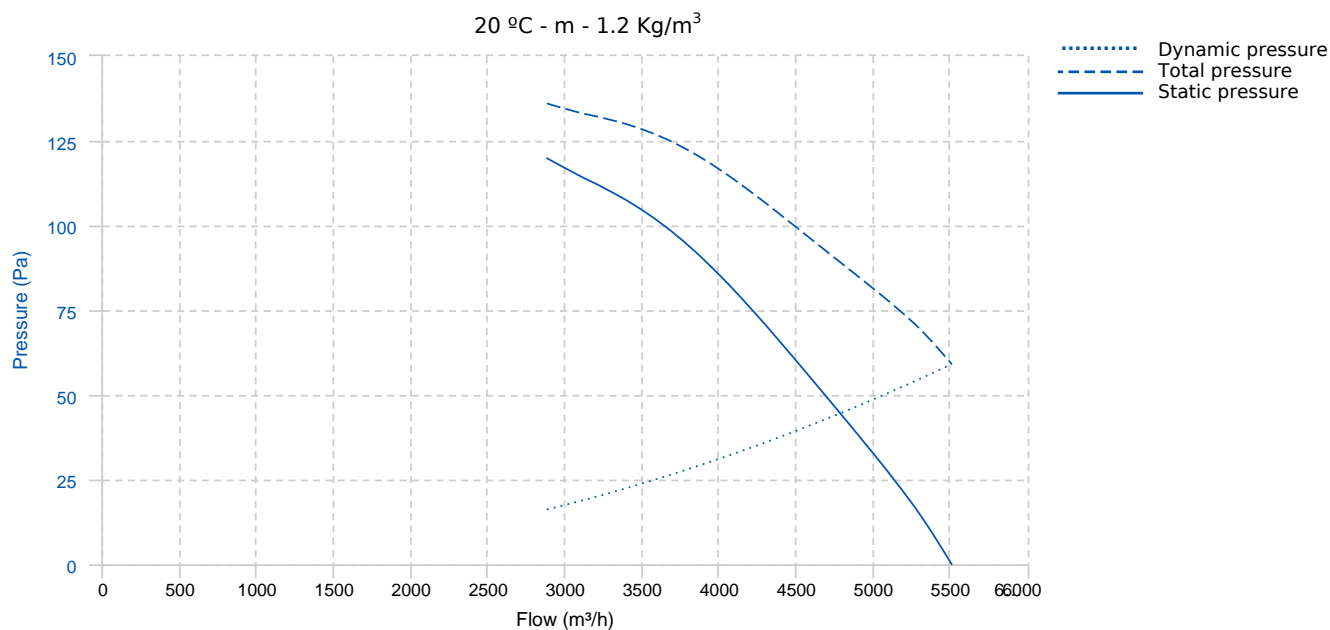

TECHNICAL DATA

Fan							
RPM	1370	Approx. weight	39 kg	Max. Flow	5520 m ³ /h		
Motor							
Power	0,37 kW	RPM	1370	I max. (230V)	1,86 A	I max. (400V)	1,07 A
Size	71	Approx. weight	6.2 kg	Efficiency (%)	69.5 %		

DIMENSIONS

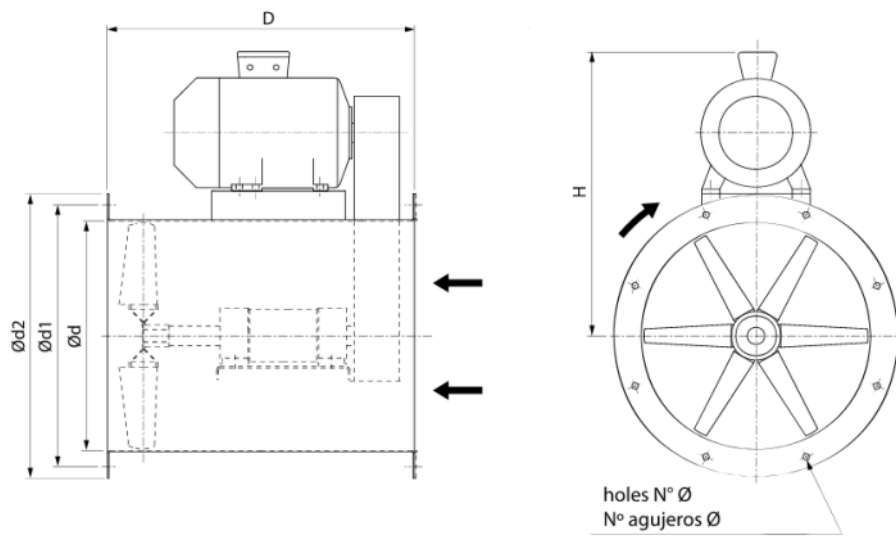

Dimensions (mm)									
D	475	H	460	N	12	d	450	d1	497
d2	535	Ø	12						

WIRING DIAGRAM

230V 

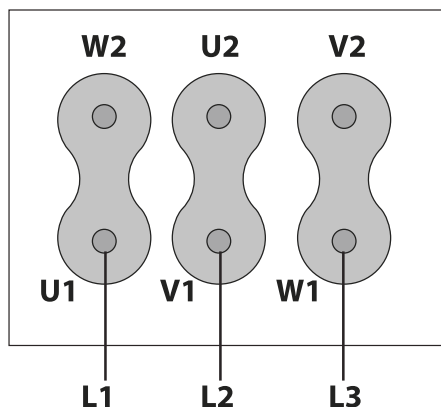

400V 

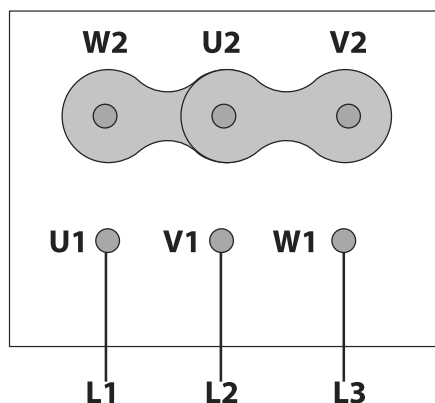

ACCESSORIES



CONNECTION FLANGE
AC 450
REF: 960003213



ANTI-VIBRATION JOINT
JE 45
REF: A-300719201

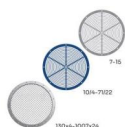

INLET PROTECTION GUARD FOR CENTRIFUGAL FANS
RA 455x12
REF: A-510004501



CIRCULAR-CIRCULAR ANTI-VIBRATION FLANGE
BAD 12 (Ø450)
REF: 960003462



FREQUENCY SPEED CONTROLLER
SFC 230 I 2,5A *
REF: SFC230I003



FREQUENCY SPEED CONTROLLER
SFC 400 III 1,2A *
REF: SFC400III1